

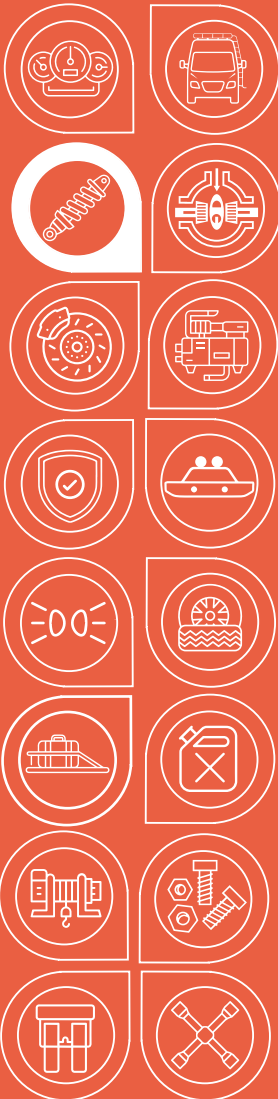

**AGILE
OFFROAD**
SMARTER THAN DIRT



Installation Guide

SPRINTER 3500 1-3/8" LIFT BLOCK
LEVELING KIT BY AGILE OFFROAD

AO-S7S-2

LEVEL OUT YOUR LOAD WITH A REAR LIFT BLOCK KIT

3500 1-3/8" LIFT BLOCK LEVELING KIT
FOR SPRINTER BY AGILE OFFROAD



Designed specifically for Mercedes-Benz Sprinter 3500 vans, the Agile Offroad 1-3/8" Lift Block Leveling Kit is the perfect solution for leveling the rear of your vehicle—whether to balance the front lift or accommodate heavier loads.

The kit includes powder-coated steel brackets and integrates OEM-style lift blocks, ensuring strength, corrosion resistance, and factory-style compatibility. It's a popular upgrade for Sprinter 3500 owners who've added front suspension upgrades or want a more level stance for improved ride quality, especially when towing or hauling gear.

SKU

AO-S7S-2

PARTS INCLUDED

2 x 1 3/8" Lift Block

1 x Bump Stop Spacer Bracket Right Side

1 x Bump Stop Spacer Bracket Left Side

TOOLS NEEDED

18mm Socket

18mm Wrench

19mm Socket

21mm Socket

INSTALLATION TIME

1 Hour

NOTE: A U-bolt kit may be required depending on your leaf springs and block height. Be sure to measure your setup beforehand and account for any extra length your current U-bolts can accommodate.

Refer to the Owner's Manual for proper jacking points. Use a lift to support the vehicle using factory Mercedes recommended safety procedures.

INSTALLATION GUIDE



1. Safely lift the vehicle using the Mercedes recommended lift points. Use an 18mm wrench and socket to remove the two sway bar link nuts and bolts.

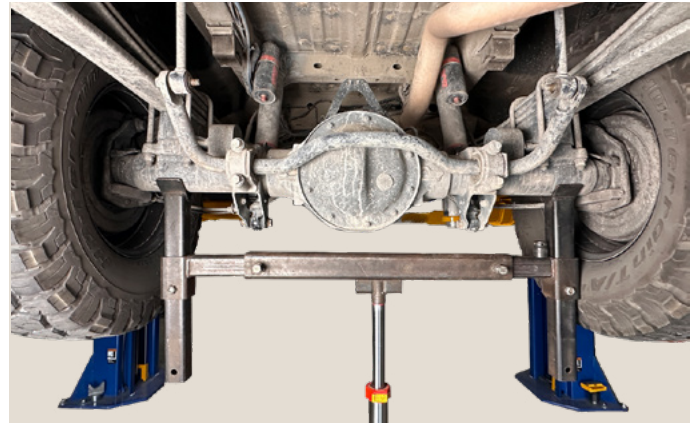

2. Use a hydraulic jack to support the axle.

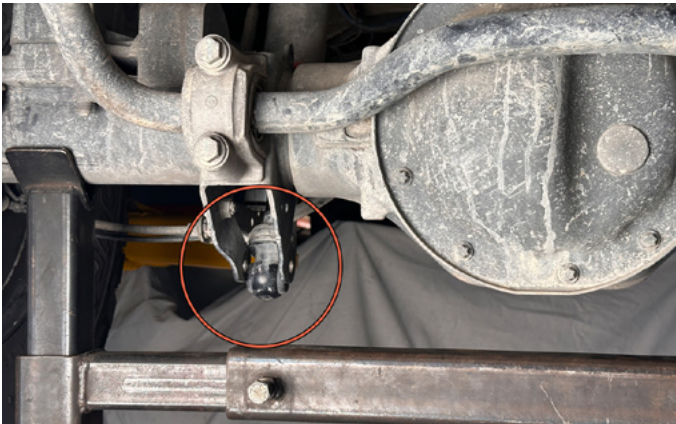

3. Use a 21mm wrench and socket to remove the two lower shock nuts and bolts.

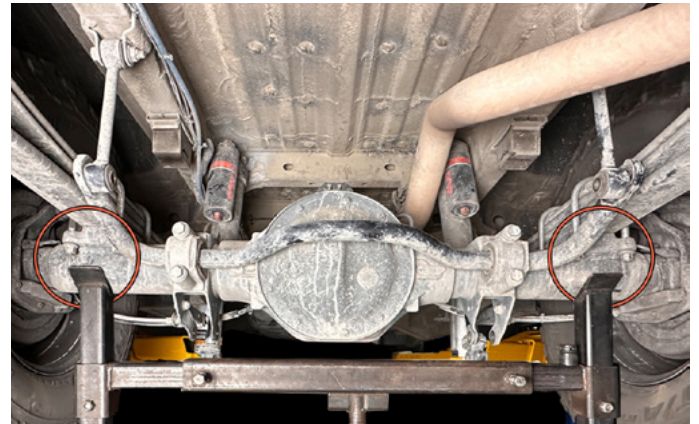

4. With the axle supported, loosen (DO NOT REMOVE) the four u-bolts at both left and right leaf springs.



5. Use a 19mm socket to completely remove the u-bolts on one side only.



6. Lower the hydraulic jack to separate the axle from the leaf spring.

INSTALLATION GUIDE



7. Install the supplied lift block making sure the block pin inserts into the axle spring pad.



8. Lift the hydraulic jack to lift the axle making sure the lower leaf spring pin inserts into the lift block hole. Install the u-bolts.



9. Install the u-bolt nuts. Do not completely tighten. **Note: There should be a minimum of a 1/4" of threads exposed past the nut.**

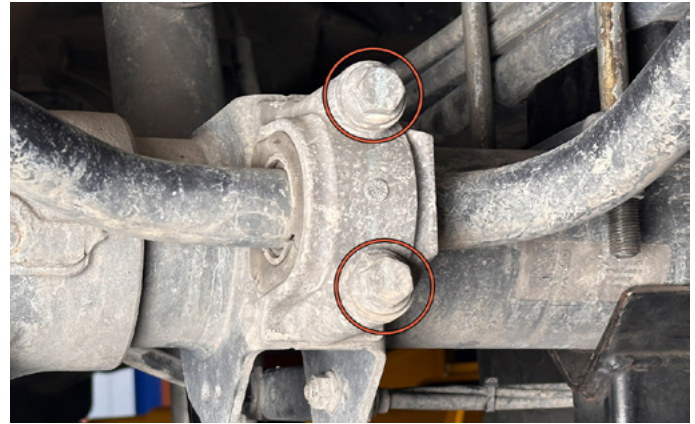

10. Use a 18mm socket to remove the two sway bar D-Shaped bracket bolts.



11. Slide the Bump Stop Spacer tab between the axle and the sway bar bracket. Re-install the factory hardware. Torque to 45 ft/lbs. Repeat steps 5-11 on the opposite side.

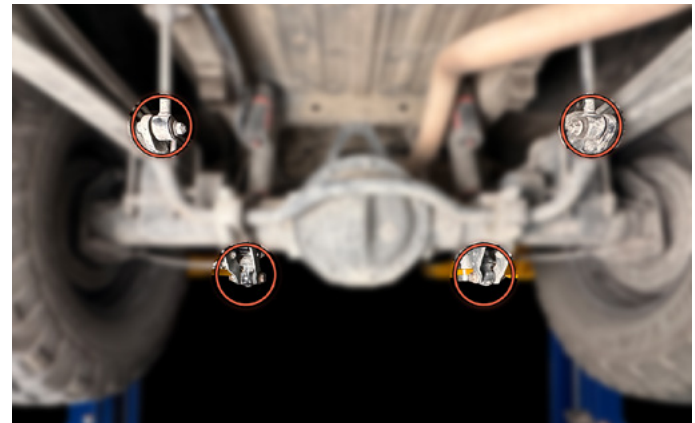

12. Re-install the lower shock nuts and bolts. Torque to 81 ft/lbs. Re-install the sway bar link nuts and bolts. Torque to 40 ft/lbs. Carefully lower and remove the hydraulic jack and then lower the vehicle to the ground. Let the suspension settle and then fully tighten the four u-bolts. Torque to 140 ft/lbs. Retorque u-bolts after 500 miles.



 **AGILE
OFFROAD**
SMARTER THAN DIRT



Interior



Exterior



Suspension



Air Locker &
Drivetrain



Steering &
Brakes



Air
Compressors



Armor &
Protection



Bumpers



Lighting



Wheels &
Tires



Storage &
Racks



Water &
Fuel Tanks



Winches &
Recovery



Replacement
Parts &
Accessories



Electrical



Tools

