

INSTALLATION GUIDE



**AGILE
OFFROAD**
SMARTER THAN DIRT®

GRENADIER STEERING STABILIZER

GENERAL INFORMATION

The AO/Fox Steering Stabilizer for the Ineos Grenadier is valved to soften the steering and improve the driving experience, making your Grenadier easier to control over any terrain. We recommend the steering stabilizer be installed by an authorized AO dealer (refer to agileoffroad.com to find a dealer near you).

****Read the instructions completely before starting the installation process.****

PARTS INCLUDED

Part # AGA1001:
1 x Steering Stabilizer
2 x 15mm ID Thick Washers
2 x 12mm Conical Washers
1 x 12mm Thick Washer
1 x Red Loctite Capsule

TOOLS NEEDED

18mm Socket Wrench
21mm Socket/Wrench (2 required)
Torque Wrench



1. The installation of the AO/Fox Steering Stabilizer can be performed with the vehicle on flat ground. Use a 18mm socket/wrench to remove the passenger side bolt. On the driver side, use two 21mm socket/wrenches to remove the nut and bolt. Completely remove the OEM steering stabilizer. The mounting hardware will be re-used.

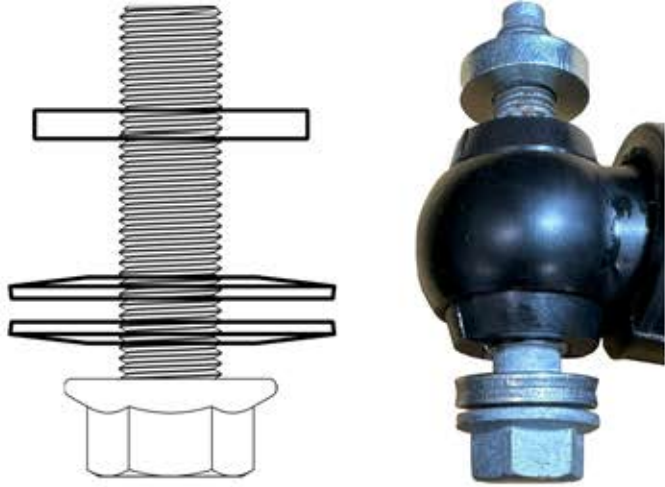

2. Use the two supplied conical washers and the 12mm ID thick washer to install the AO/Fox Steering Stabilizer to the passenger side factory location. ***Note the orientation of the conical washers.*** Apply a small drop of the supplied red loctite to the factory bolt and install hand tight.

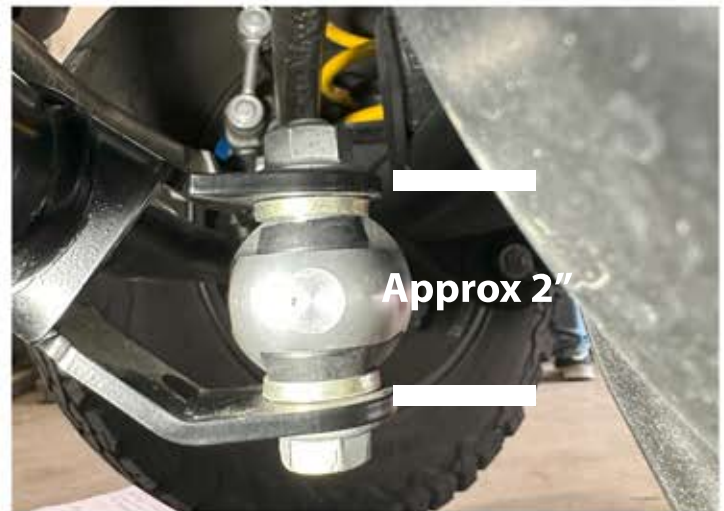
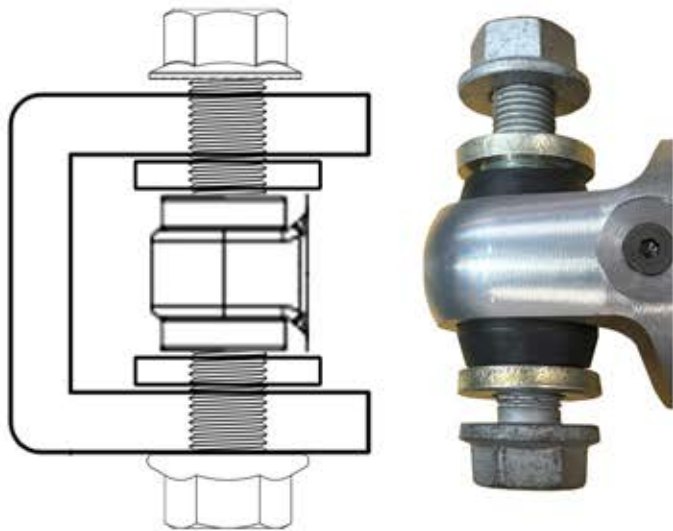

3. Use the two supplied 15mm ID thick washers to install the AO/Fox steering stabilizer to the driver side factory location. ***Note: It may be necessary to slightly pry open the oem mount to fit the new stabilizer.*** Apply a small drop of the supplied red loctite to the factory bolt and install using the factory nut.

****Tech Tip: After installing one side of the steering stabilizer, turn the steering wheel to align up the opposite side to the mounting bracket****



4. Torque the passenger side bolt to 75 ft lbs and the driver side bolt and nut to 110 ft lbs. Test cycle the steering lock to lock before driving.