

INSTALLATION GUIDE

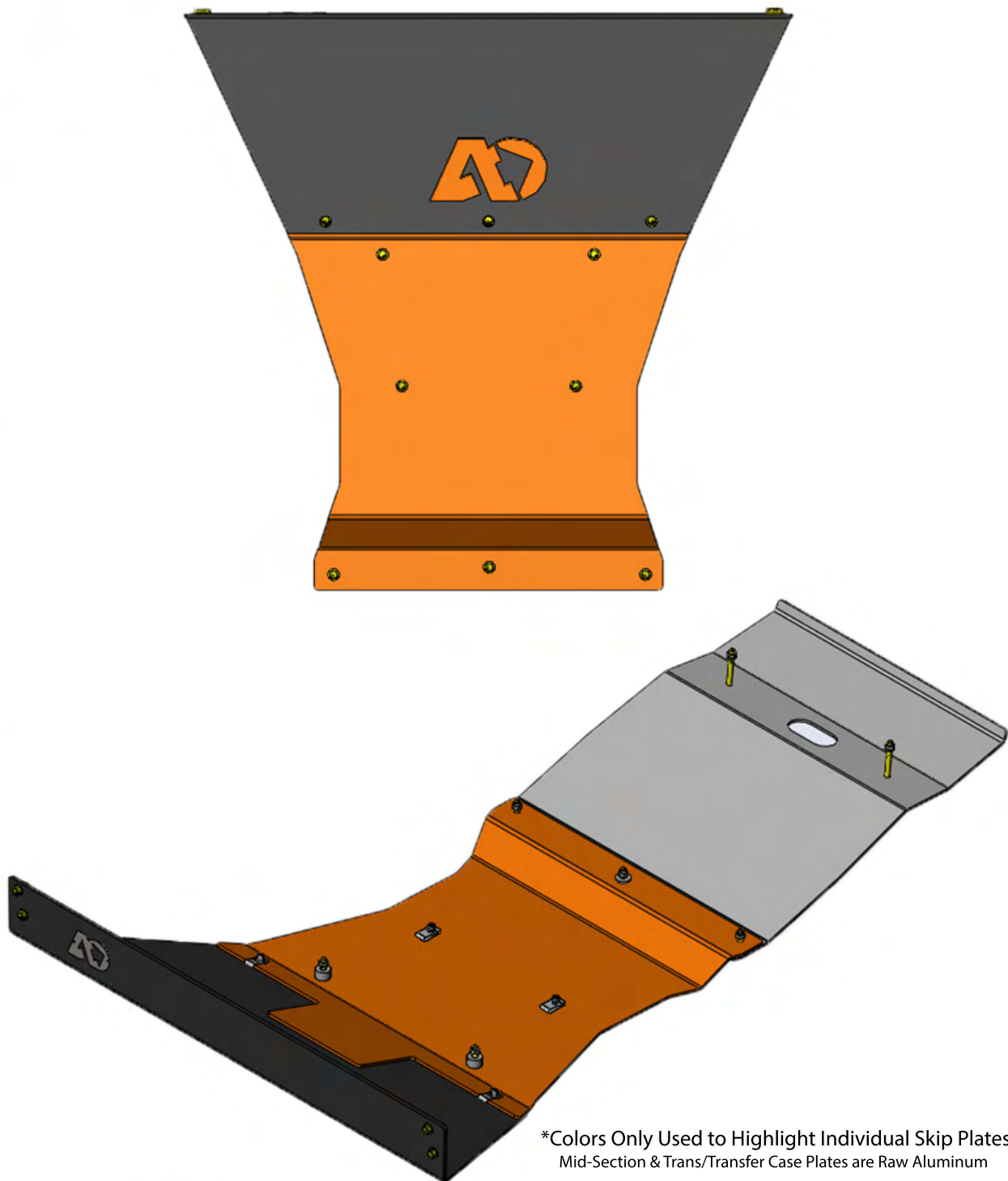

**AGILE
OFFROAD**
SMARTER THAN DIRT®

2023+ AWD SPRINTER SKID PLATES

GENERAL INFORMATION

The AO Sprinter 2023+ AWD Skid Plate Package is specially designed as a bolt-on application on the AWD Sprinter 144 and 170 vans. The skid plates are made from 3/16" 6061 T6 aluminum and have a high strength to weight ratio giving your van excellent protection while keeping the weight to a minimum.

****Read the instructions completely before starting the installation process.****

PARTS INCLUDED

Part # AOR4023 Engine Skid Plate:

1 x AO Front Engine Skid Plate (Blk, Orange, Raw)

1x AO Mid-Section Skid Plate (Raw Alum.)

6 x M8x1.25 Flange Nut

9 x M8x1.25x25 Bolts

3 x M8x1.25x30 Bolts

2 x M8x1.25x40 Bolts

3 x M8x1.25 Clip-On Barrel Nut

2 x 16mm Spacers

Part # AOR4024 Trans/Transfer Case Skid Plate:

1 x AO Tran/Transfer Case Skid Plate (Raw Alum.)

2 x M8x1.25x70 Bolts

2 x M8x1.25 Flange Nuts

1 x 3/8" Drill Bit

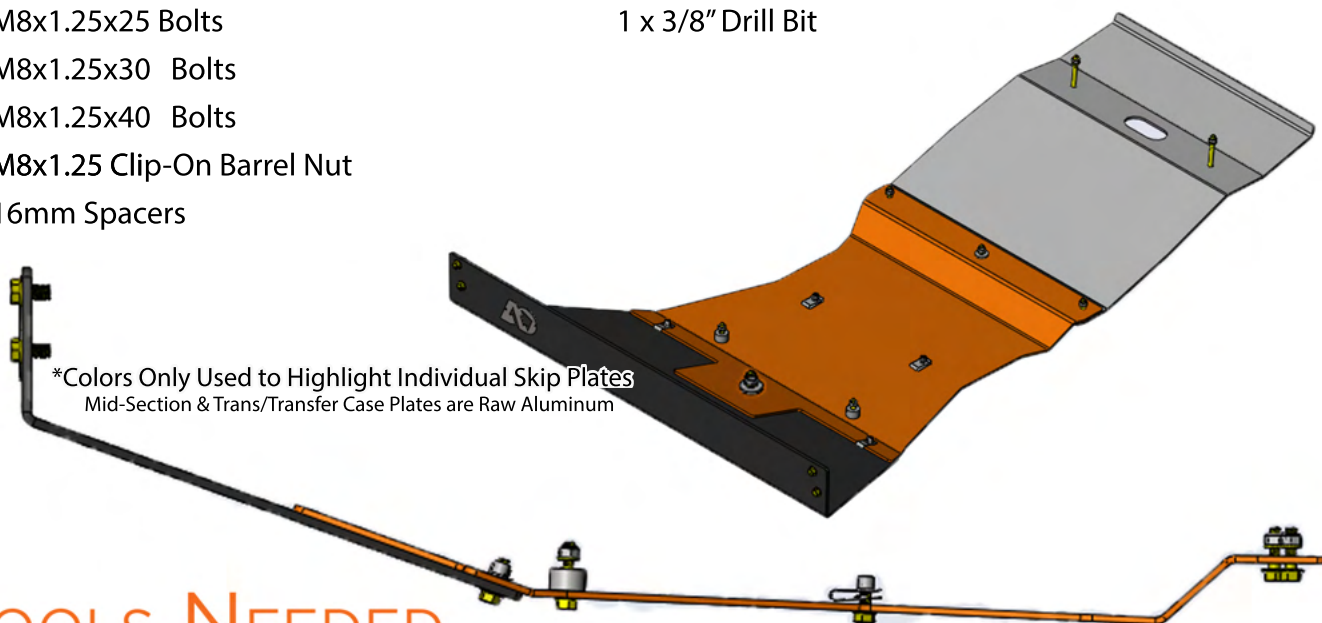

*Colors Only Used to Highlight Individual Skid Plates
Mid-Section & Trans/Transfer Case Plates are Raw Aluminum

TOOLS NEEDED

12mm wrench/socket

13mm wrench/socket

Drill



1. Use a 13mm wrench/socket to remove the lower radiator support bracket.



2. Install 2 of the supplied clip-on barrel nuts to the suspension crossmember. Line up the barrel nuts to the existing holes on the crossmember.

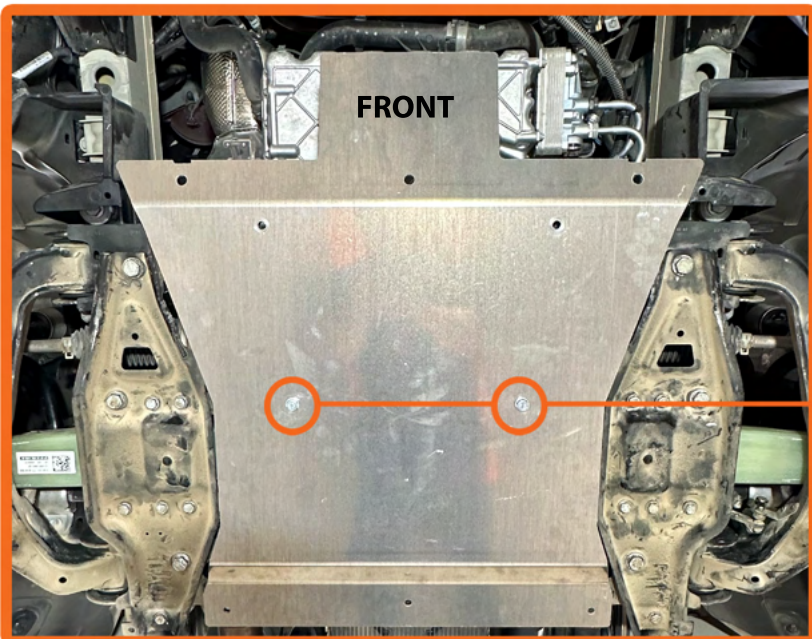

3. Install the mid-section skid plate as shown using the supplied M8x1..25x25 bolts. These bolts will go into the clip-on barrel nuts installed onto the suspension crossmember. Hand tighten only at this time.



4. Install the two supplied 16mm spacers as shown. Line up spacers to the mid-section skid plate holes and existing crossmember holes. Install the two supplied M8x1.25x40 bolts and M8x1.25 flange nuts from the bottom of the skid plate up through the spacers and crossmember. Hand tighten only at this time.

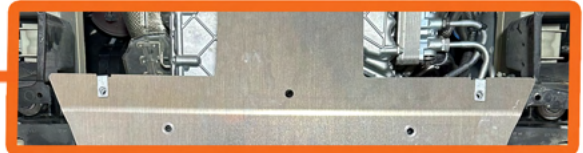
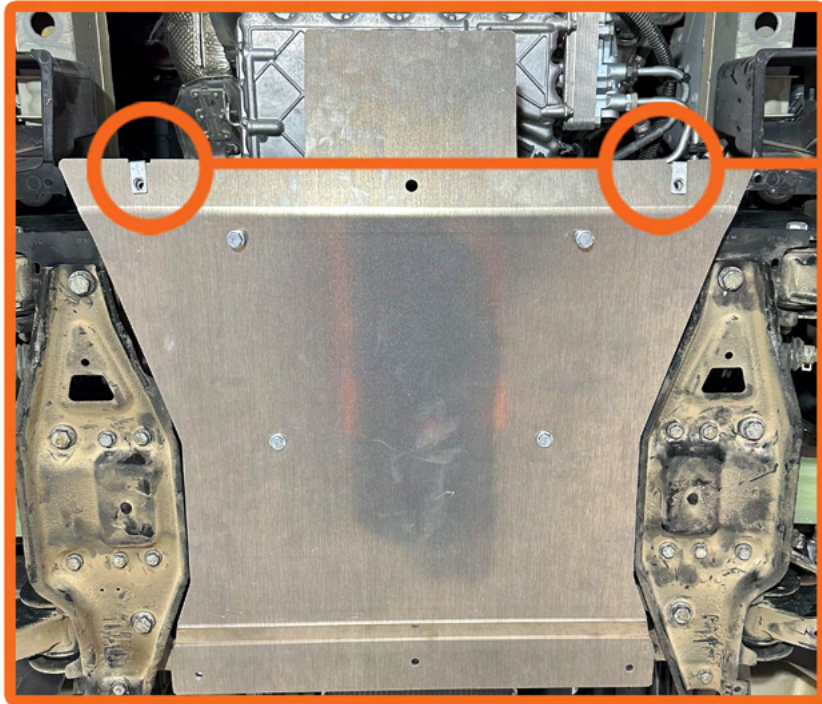

5. Install two of the supplied clip-on barrel nuts to the front of the mid-section skid plate as shown.

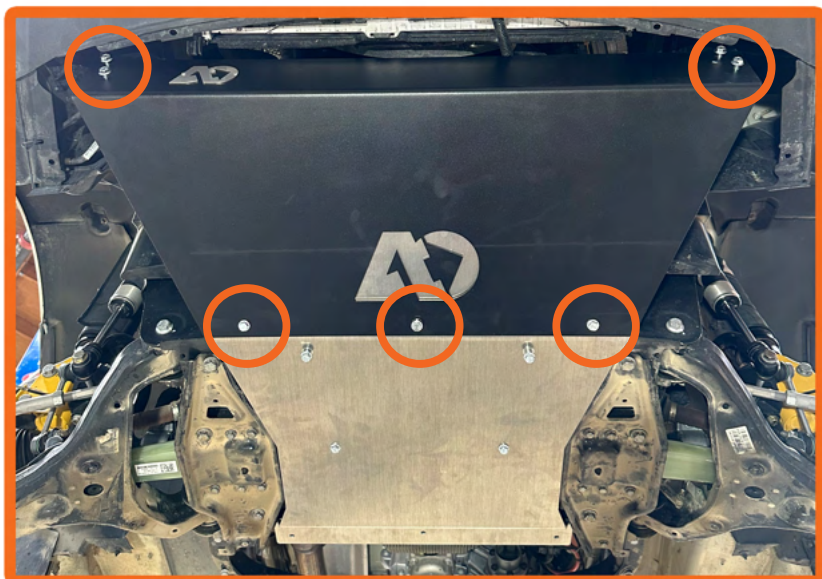

6. Install the front engine skid plate using 7 of the supplied M8x1.25x25 bolts. The front 4 bolts go into the factory override brackets, 2 bolts go into the clip-on barrel nuts, and the center bolt will use one of the supplied M8x1.25 flange nuts. Hand tighten only at this time.

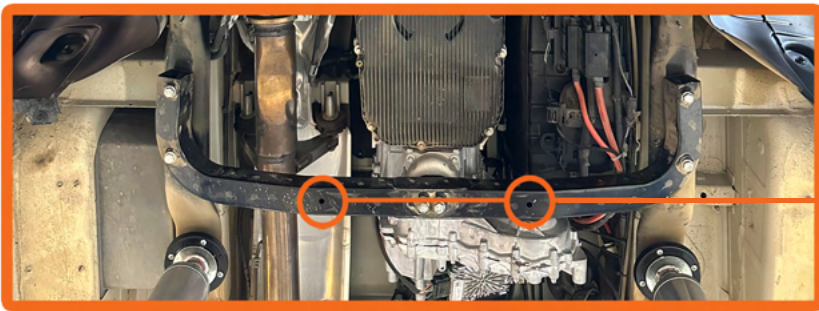

7. Use the existing transmission crossmember holes as guides and drill completely through the crossmember. A 3/8" drill bit is supplied.

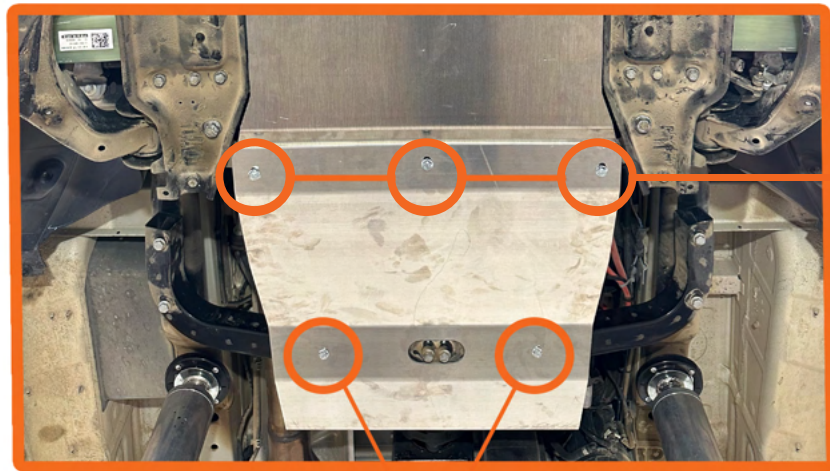

8. Use three of the M8x1.25x30 bolts and three M8x1.25 Flange nuts to install the transmission/transfer case skid plate. Hand tighten only at this time.



9. Use the two supplied M8x1.25x70 bolts and two flange nuts to install the rear of the transmission/transfer case plate to the transmission crossmember. Hand tighten only at this time.

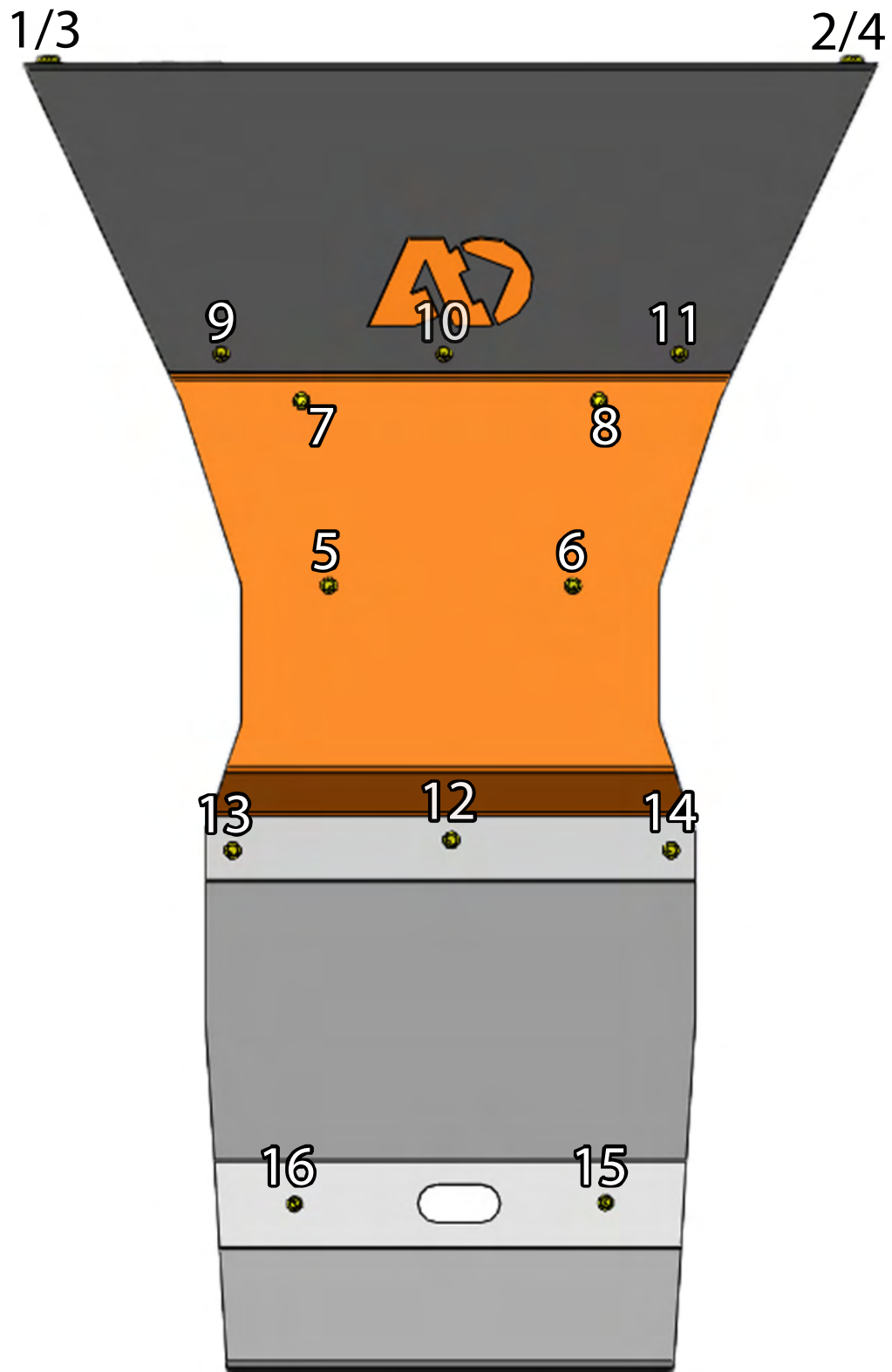

10. Tighten all the bolts following the sequence above. All bolts require a 13mm wrench/socket except for the rear transmission/transfer case plate to transmission crossmember bolts that require a 12mm wrench/socket. Torque all bolts to 23 ft lbs.